

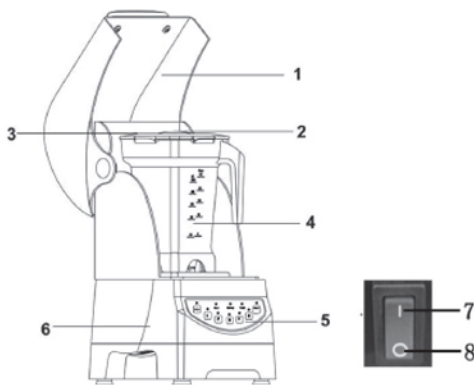

Q4500



- 1: Sound Cover 2: Central cover 3: Blender Cup Cover
- 4: Blender Cup 5: Control Panel
- 6: Body 7: Power On 8: Power Off
- 1, 2, 3, 4 and 5: Speed Mode

### Specifications

Size	210 * 220 * 470 mm
Weight	6.0 kg
Power	2000 W 3.0 HP
Speed	RPM: 30000
Material	Plastic/Steel
Knives	Carbon Steel
Controls	Touch buttons
Noise reduction	Sound Cover < 80db
CE Certificate	Yes
Container	1,0 > 1,5 l. BPA free

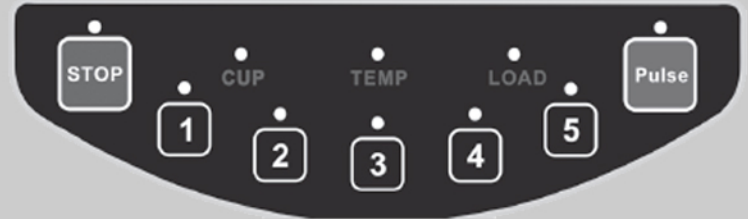

1, 2, 3, 4, 5: Speed mode

**CUP:** If cup was not on base or not on correct position, the light will twinkle.

**TEMP:** If motor was over temperature, the light will twinkle.

**LOAD:** If motor was over loaded, the light will twinkle.

**Mode 1:**  
15000 rpm for 18s

**Mode 2:**  
0-2s:13000rpm; 2-5s:11000rpm; 5-8s:15000rpm;  
8-11s:20000 rpm; 11-25s: 30000 rpm.

**Mode 3:**  
0-2s:13000 rpm; 2-4s: 14500 rpm; 4-6s:18000 rpm  
6-15s: 20000 rpm; 15-30s:30000rpm

**Mode 4:**  
15000 rpm; 8-11s:13000 rpm; 11-25s: 18000 rpm  
25-35s: 25000rpm.

**Mode 5:**  
15000 rpm; 9-11s: 16000 rpm; 11-14s: 20000rpm  
14-50s: 30000rpm..

### PULSE CONTROL

Hold the PULSE button down, it will drive the motor and blade at its fastest speed and highest torque. When you let go of the pulse feature, the blender stops. The Pulse Button is also great for chopping down ice cubes into crushed ice or slush.